

# Down The Hole Drilling Tools

--Overburden Drilling System



## Contents

<b>Eccentric casing System</b> _____	<b>3-5</b>
(ODEX) with three pieces_____	<b>4</b>
(ODEX) with two pieces_____	<b>5</b>
<b>Concentric Casing Systems</b> _____	<b>6-13</b>
With Ring Bits_____	<b>7</b>
With Wings _____	<b>10</b>
With Blocks _____	<b>11</b>
Double Casing Drilling Tools _____	<b>12</b>



## Eccentric casing System

**Application Range:** It is suitable for drilling water wells, geothermal wells, Micro piles, medium mini-type grouting hole of building, dam and harbor project.

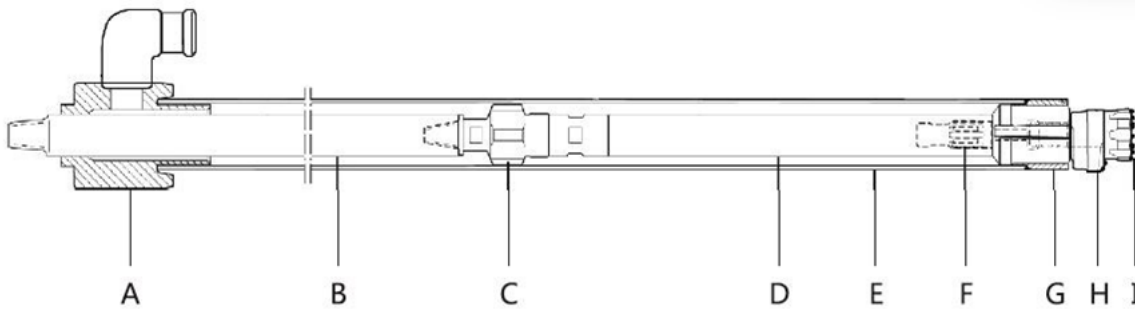

**Design Principles:** Make the casing follow easy and the equipment and operation simple.

**Outstanding Advantages:** Simple structure, easy operation, reliable quality, retrievable drilling tools, and long service life.

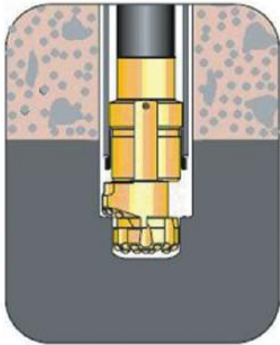
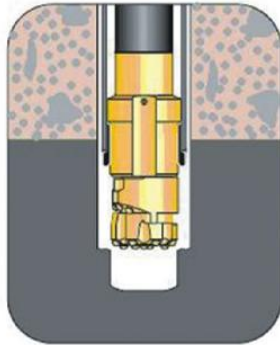
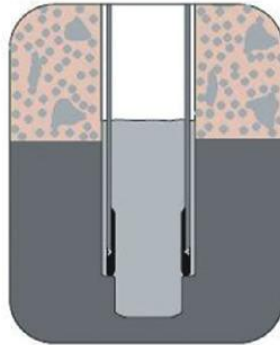

- A: Discharge Head    B: Drill Rod    C: Guide Sleeve  
 D: DTH Hammer    E: Casing Tube    F: Guide Device  
 G: Casing Shoe    H: Reamer    I: Pilot Bit

### Operation Procedure

			
<p>1. As soon as the drilling starts, the reamer opens and enlarges the hole to drive the casing shoe and casing tube down.</p>	<p>2、 When drilling in overburden formation is done, Start reverse circulation to close the reamer, and then pull up the assembly through the casing tube.</p>	<p>3、 The casing tube can be left in the hole, or can be pulled out by means of grout sealing material.</p>	<p>4、 Use the normal drilling tools to drill and achieve to the desired depth.</p>

### ODEX System--- Eccentric casing with three pieces

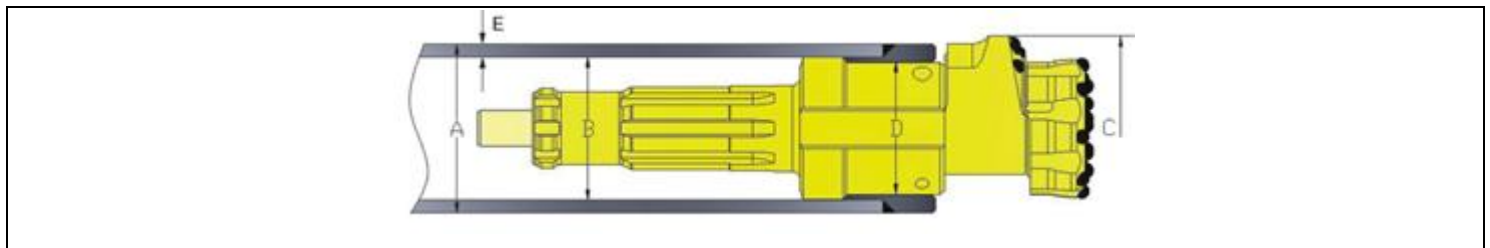
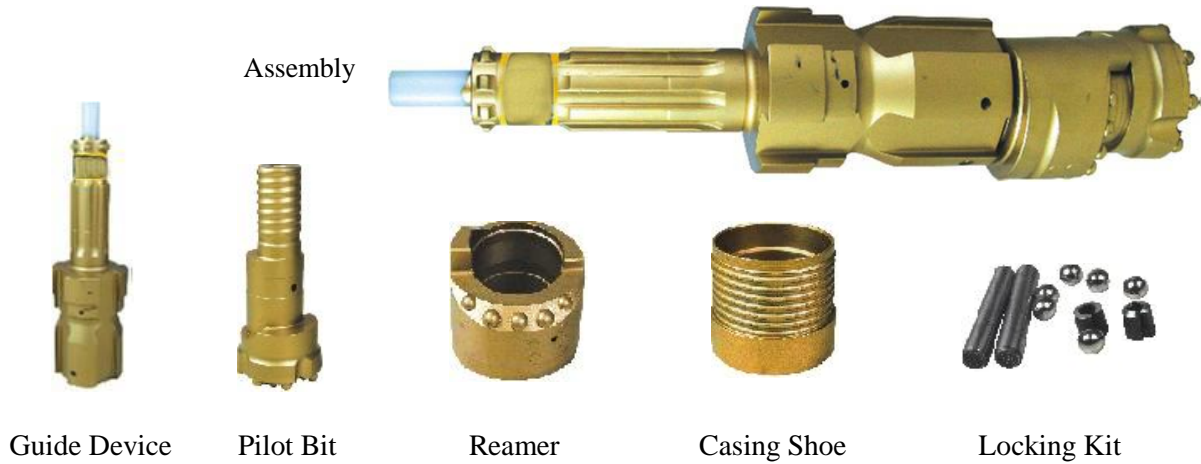

	A	E	C	D		Drill pipe
System No.	Outer Dia.	Thickness Range	Reamed Dia.	Min.Inner Dia.of Casing Shoe	Hammer Type	Drill Pipe Range
KE85	108mm (4.25")	9 -15 mm (0.35")-(0.59")	118 mm (4.65")	86 mm (3.4")	DHD3.5, COP32, COP34	76 mm (3")
KE90	114 mm (4.5")	11 – 13mm (0.43")-(0.51")	127 mm (5")	91 mm (3.6")	DHD 3.5, COP32 COP34	76 mm (3")
KE102	127 mm (5")	11 mm – 13 mm (0.43") – (0.51")	136 mm (5.35")	101 mm (3.97")	DHD 3.5, COP32 COP34	76 mm (3")
KE115	140 mm (5.5")	13 mm – 16 mm (0.51") – (0.63")	152 mm (5.98")	117 mm (4.6")	DHD340, QL 40 SD-4	76mm (3")
KE115A	146 mm (5.75")	14 mm - 19 mm (0.55")-(0.75")	154 mm (6")	117 mm (4.6")	DHD340, QL 40, SD-4 COP 42/44	76 mm (3")
KE140	168 mm (6.6")	13 mm – 19 mm (0.51") – (0.75")	184 mm (7.25")	140 mm (5.5")	DHD350, QL50 / SD-5 COP52/54	76 mm- 89mm (3") – (3.5")
KE150	178 mm (7")	13 mm – 19 mm (0.51") – (0.75")	194 mm (7.63")	150 mm (5.90")	DHD350, QL50 / SD-5	76 mm – 89 mm (3") – (3.5")
KE165	193 mm (7.6")	13 mm – 20 mm (0.51")-(0.78")	206 mm (8.11")	165 mm (6.5")	DHD360, QL60 / SD-6	89 mm –114mm (3.5") – (4.5")
KE190	219 mm (16.5")	13mm – 20mm (0.51") – (0.78")	234 mm (9.21")	193 mm (7.6")	DHD360 QL60, SD-6	89 mm –114mm (3.5") – (4.5")
KE210	245 mm (9.64")	14 mm -21 mm (0.55") – )0.85")	260 mm (10.25")	210 mm (8.25")	DHD360/380, QL 60/80 SD-6/SD-8	114 mm (4.5")
KE240	273 mm (10.75")	16 mm – 22 mm (0.63") – (0.83")	300 mm (11.8")	240 mm (9.5")	DHD380, QL80 SD-8	114mm-127mm (4.5") – (5")

**ODEX SYSTEM--- Eccentric casing with two pieces**

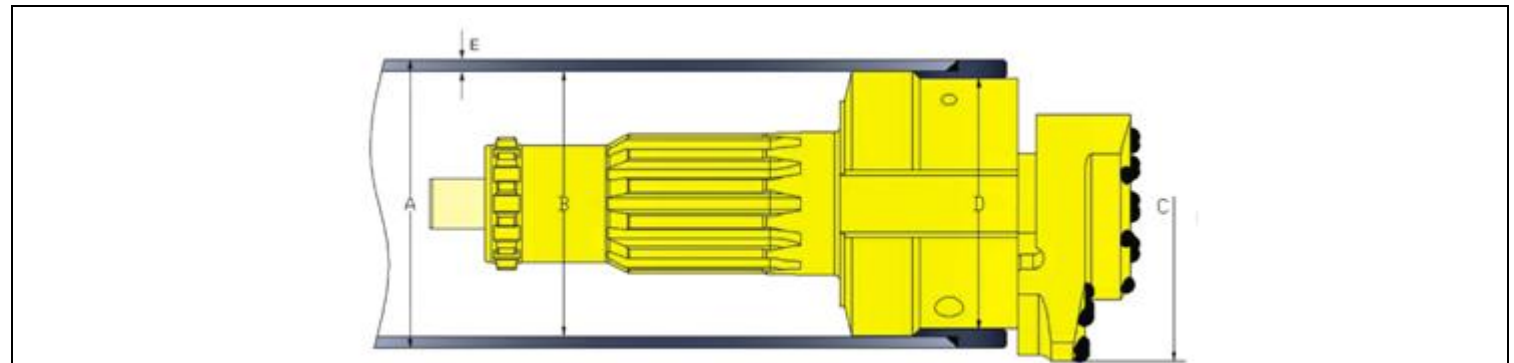

	CasingPipe		Reamer dia.	Casing shoe	DTH Hammer	Drill Pipe
	A	E	C	D		
System No.	Outer Dia.	Thickness	Reamed Dia.	Min. Inner Dia. of Casing Shoe	Hammer Type	Drill Pipe
K188	178 mm (7")	13 mm – 19 mm (0.51")–(0.75")	188 mm (7.4")	144 mm (5.7")	DHD350 QL 50, SD-5, COP52/54	76mm- 89mm (3") – (3.5")
K240	219 mm (8.62")	12 mm- 15mm (0.47")–(0.59")	240 mm (9.45")	192 mm (7.5")	DHD360, QL 60, SD-6,	114 mm (4.5")
K305	273 mm (10.75")	16 mm-20mm (0.63")–(0.78")	305 mm (12")	238 mm (9.4")	DHD380, QL 80, SD-8	114mm-127mm (4.5") – (5")
K360	323mm (12.7")	20 mm – 24 mm (0.78") – (0.94")	360 mm (14.17")	284 mm (11.8")	DHD380, QL 8, SD-8/10	127 mm (5")



## Concentric Casing Systems

### Application Range:

It is recommended to drill in rock formation where contains some ovals and fractures.

### Design Principles:

The stable and reliable working performance and the less vibration of drill rig.

### Different Structures:

Concentric system with ring bits, wing and blocks.

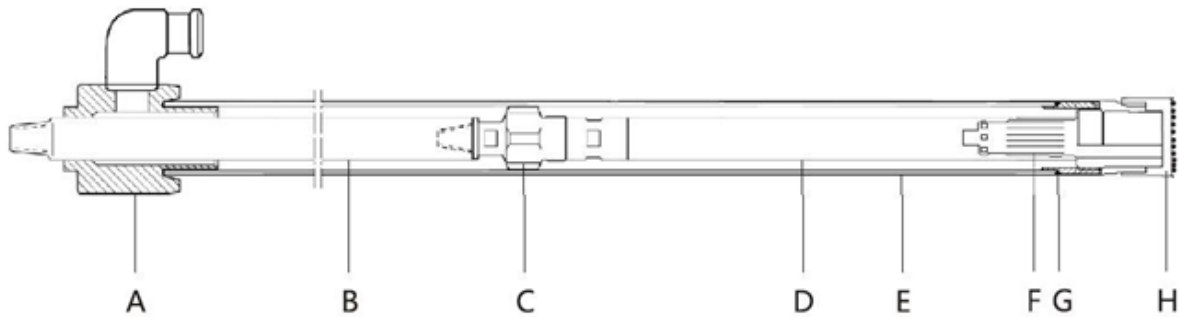

- |                   |                |                 |
|-------------------|----------------|-----------------|
| A: Discharge Head | B: Drill Rod   | C: Guide Sleeve |
| D: DTH Hammer     | E: Casing Tube | F: Pilot Bit    |
| G: Casing Shoe    | H: Ring        |                 |

**With Ring Bits**



Pilot



Ring Bit



Assembly

**Permanent**

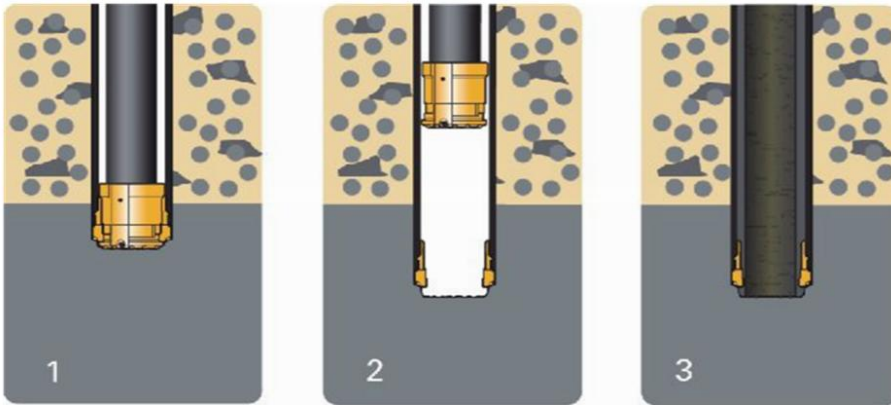

1. When drilling starts, the pilot bit drive the ring bit down to the hole, followed the casing shoe and casing tube.

2. At the bedrock, start Reverse circulation of tools and pull the pilot bit from the drill hole leaving the ring bit in the hole.

3. Pour the concrete or do the next constructions work.

**Retrievable**

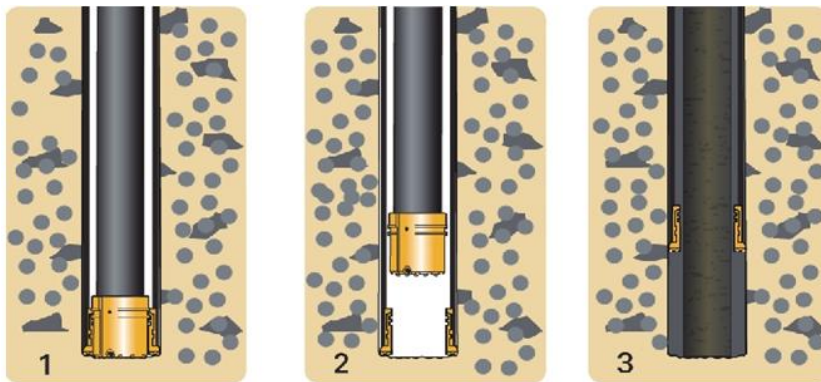

1. After the drilling starts, the pilot bit drive the ring bit down to the hole, followed the casing shoe and casing tube.

2. At the bedrock, start Reverse circulation of tools and pull the pilot bit back from the drill hole leaving the ring bit in the drill hole.

3. Pull the casing tube out with the ring bit and at the same time pour the concrete.

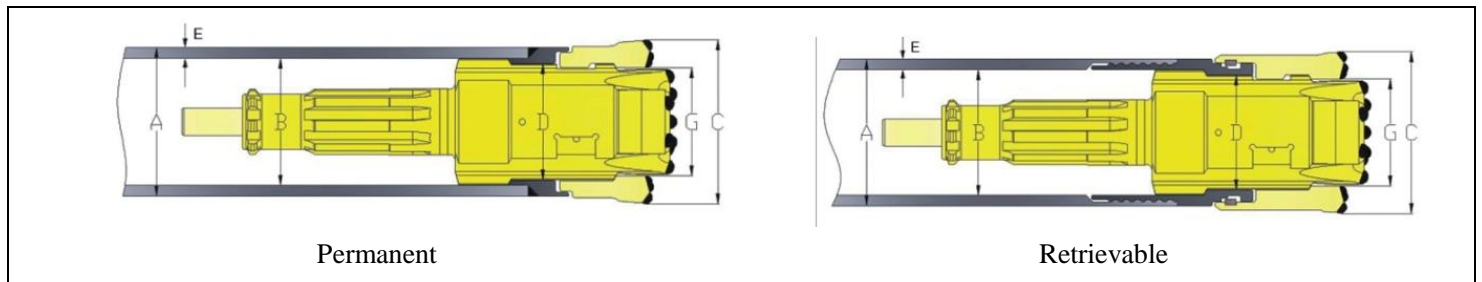

	A	E	C	D			G
System No.	Outer Dia.	Thickness Range	Ring bit Outer Dia	Pilot bit Outer Dia	Hammer Type	Drill Pipe Range	Ring Bit Inner Dia.
KC85	108 mm (4.25")	9-15mm (0.35")-(0.59")	118mm (4.65")	86 mm (3.4")	DHD 3.5	76 mm (3")	77 mm (3.03")
KC90	114 mm (4.5")	11-13 mm (0.43")-(0.51")	127 mm (5")	90 mm (3.6")	DHD 3.5 COP32/34	76 mm (3")	82 mm (3.22")
KC102	127 mm (5")	11-13 mm (0.43")-(0.51")	136 mm (5.35")	102 mm (3.97")	DHD3.5 COP32/34	76 mm (3")	92 mm (3.62")
KC115	140 mm (5.5")	13-16 mm (0.5")-(0.63")	152 mm (5.98")	115 mm (4.6")	DHD340 QL 40, SD-4	76 mm (3")	105 mm (4.14")
KC115A	146mm (5.75")	14-19mm (0.55")-(0.75")	154 mm (6")	115 mm (4.6")	DHD340, QL 40, SD-4	76 mm (3")	105 mm (4.14")
KC140	168 mm (6.6")	13-19 mm (0.51")-(0.75")	184 mm (7.25")	140 mm (5.5")	DHD 350 QL 50, SD-5	76mm (3")	125 mm (4.92")
KC152	178 mm (7")	13-19 mm (0.51")-(0.75")	194 mm (7.65")	150 mm (5.9")	DHD350 QL50, SD-5	76, 89 mm (3"),(3.5")	140 mm (5.5")
KC165	193 mm (7.6")	13-20 mm (0.51")-(0.78")	206 mm (8.11")	165 mm (6.45")	DHD 360 QL 60, SD-6	89, 114 m (3.5"),(4.5")	150 mm (5.90")
KC185	219 mm (8.62")	13-20mm (0.51")-(0.78")	234 mm (9.2")	184 mm (7.25")	DHD 360 QL 60, SD-6	89, 114 mm (3.5"),(4.5")	165 mm (6.5")
KC210	244 mm (9.6")	13 - 20 mm (0.51")-(0.78")	260 mm (10.25")	210 mm (8.25")	DHD360/80 SD-6/8, QL 60/80	114 mm (4.5")	190 mm (7.5")
KC240	273 mm (10.75")	16- 22 Mm (0.63")-(0.83")	305 mm (12")	240 mm (9.45")	DHD380, QL 80, SD-8	114, 127mm (4.5"),(5")	220 mm (8.7")



KC280	323 mm (12.7")	13– 22 mm (0.51")-(0.86")	348 mm (13.7")	284 mm (11.2")	DHD 380, QL 80, SD 8/10	127 mm (5")	255 mm (10")
KC365	406 mm (16")	18 -24 mm (0.70")-(0.94")	440 mm (17.32")	364 mm (14.33")	DHD112 QL 120, SD-10/12	140 mm (5.5")	340 mm (13.4")
KC410	457 mm (18")	18 – 24 mm (0.70")-(0.94")	488 mm (19.2")	413 mm (16.25")	DHD 112 QL 120, SD-12	140 mm (5.5")	385 mm (15")
KC465	508 mm (20")	18-24mm (0.70")-(0.94")	538 mm (21.2")	464 mm (18.25")	DHD 112 QL 120/200, SD-15/18	140 mm (5.5")	440 mm (17.3")
KC510	558 mm (22")	18 – 24 mm (0.70")-(0.94")	590 mm (23.22")	514 mm (20.25")	DHD 112S,QL 120/200 SD-15/18, NUMA 180	140 mm (5.5")	485 mm (19")
KC560	610 mm (24")	18 - 24 mm (0.70")-(0.94")	642mm (25.25")	566 mm (22.25")	QL 200 NUMA180, SD-18	168 mm (6.6")	540mm (21.25")
KC615	660 mm (26")	18 – 24 mm (0.70")-(0.94")	694 mm (27.3")	615 mm (24.2")	QL200/SD-18 NUMA180	168mm (6.6")	590 mm (23.2")
KC660	711 mm (28")	18 – 24 mm (0.70")-(0.94")	745 mm (29.3")	665 mm (26.2")	QL 200, SD-18 NUMA 180/240	168mm (6.6")	640 mm (25.2")
KC715	762 mm (30")	18 – 24 mm (0.70")-(0.94")	798 mm (31.4")	716 mm (28.2")	QL 200-SD18 N180/240	168mm (6.6")	685 mm (26.95")
KC815	863 mm (34")	18 – 24 mm (0.70")-(0.94")	900 mm (35.4")	815 mm (32")	QL 200 NUMA 180/240	168mm (6.6")	785 mm (30.9")

### With Wings



### Operation Procedure

1. The wings swing out soon after the drilling start and the ream drives the casing shoes and tubes in the drill hole.
2. After completed the drilling process in overburden rock formation, as soon as the reverse drilling process start the wings will get closed, so the drilling tools can be pull back from the drill hole.
3. Follow the next drilling process.

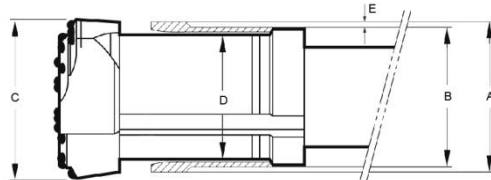

	A	E	C	D	E	
System No.	Outer Dia.	Thickness Range	Wing Bit Outer Dia.	Guide device Dia.	Hammer Type	Drill Pipes
KCC125	114 mm (4.5")	11-13mm (0.43")-(0.51")	125 mm (4.92")	93 mm (3.66")	DHD 350 COP 32/34	60 mm (2.36")
KCC152	140 mm (5.5")	13-16mm (0.51")-(0.63")	152 mm (6")	113 mm (4.45")	DHD 340 QL 40, SD-4	76 mm (3")
KCC150	146 mm (5.75")	14-19 mm (0.55")-(0.75")	154 mm (6.06")	115 mm (4.52")	DHD 340 QL 40, SD-4	76 mm (3")
KCC185	168 mm (6.6")	13-19 mm (.51")-(0.75")	184 mm (7.25")	138 mm (5.43")	DHD 350 QL 50, SD-5	76, 89 mm (3"), (3.5")
KCC190	178 mm (7")	13-19 mm (0.51")-(0.75")	194 mm (7.6")	148 mm (5.8")	DHD350/360 QL50/60,SD5/6	76, 89 mm (3"), (3.5")
KCC205	193 mm (7.6")	13-20 mm (0.51")-(0.78")	206 mm (8.11")	164 mm (6.45")	DHD360 QL 60 /SD-6	114 mm (4.5")
KCC230	219 mm (8.62")	13-20 mm (0.51")-(0.78")	234 mm (9.2")	185 mm (7.28")	DHD360 QL 60, SD-6	114 mm (4.5")
KCC275	244 mm (9.6")	13-20 mm (0.51")-(0.78")	273 mm (10.75")	219 mm (8.62")	DHD380 QL-80, SD-8	114 mm (4.5")

### With Blocks



Assembly



Pilot Bit



Blocks

### Operation Procedure

1. At the start of drilling, the blocks slides down through the grooves on pilot bit, and the ream drives the casing shoes and tubes into the drill hole.
2. After complete the drilling process in overburden rock formations, raise the drilling tools then the blocks will get closed through the grooves, the drilling tools can be pulled out from the drill hole.
3. Next construction can be followed.

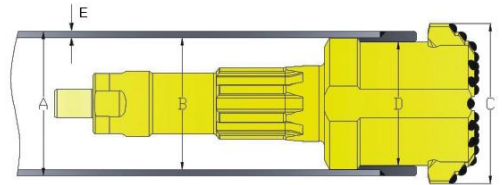

	A	E	C	D	DTH Hammer	
System No.	OuterDia.	Thickness Range	Pilot bit with Block Outer Dia.	Pilot Bit Outer Dia.	Hammer Type	Drill Pipes
KB140	168 mm (6.6")	13-19 mm (0.51")-(0.75")	184 mm (7.25")	140 mm (5.5")	DHD 350 QL 50 / SD-5	76, 89 mm (3"), (3.5")
KB150	178 mm (7")	13-19 mm (0.51")-(0.75")	194 mm (7.64")	150 mm (5.90")	DHD 350/360 QL50/60,SD5/6	76, 89 mm (3"), (3.5")
KB165	193 mm (7.6")	13-20 mm (0.51")-(0.78")	206 mm (8.11")	164 mm (6.45")	DHD 360 QL 60, SD-6	89, 114 mm (3.5"),(4.5")
KB180	219 mm (8.62")	13-20 mm (0.51")-(0.78")	234 mm (9.2")	182 mm (7.16")	DHD 360 QL 60, SD-6	89, 114 mm (3.5"),(4.5")
KB210	244 mm (9.6")	13-20 mm (0.51")-(0.78")	260 mm (10.25")	210 mm (8.25")	DHD360/380 QL-60/80, SD-6/8	114 mm (4.5")
KB240	273 mm (10.75")	16-20 mm (0.63")-(0.78")	305 mm (12")	240 mm (9.45")	DHD 380 QL 80 / SD-8	114,127mm (4.5"), (5")
KB280	323 mm (12.7")	13-22 mm (0.51")-(0.86")	348 mm (13.7")	284 mm (11.2")	DHD 380 QL-80 – SD-8/10	127 mm (5")
KB365	406 mm (16")	18-24 mm (0.70")-(0.94")	440 mm (17.32")	364 mm (14.33")	DHD 112 QL 120, SD-10/ 12	127,140mm (5"), (5.5")
KB410	457 mm (18")	18-24 mm (0.70")-(0.94")	488 mm (19.2")	413 mm (16.25")	DHD 112 QL-120/200, SD-15	127,140mm (5"),(5.5")
KB460	508 mm (20")	18-24 mm (0.70")-(0.94")	538 mm (21.2")	464 mm (18.26")	DHD 112S QL 120/200, SD-15/18	140 mm (5.5")
KB510	558 mm (22")	18-24 mm (0.70")-(0.94")	590 mm (23.2")	514 mm (20.2")	DHD 112S QL 120/200, SD-15/18, N180	140 mm (5.5")
KB560	610 mm (24")	18 - 24 mm (0.70")-(0.94")	642 mm (25.25")	566 mm (22.3")	QL 200, SD-18, NUMA 180	140, 168mm (5.5"),(6.6")
KB615	660 mm (26")	18 - 24 mm (0.70")-(0.94")	694 mm (27.3")	615 mm (24.2")	QL 200, SD-18 NUMA 180/240	168mm (6.6")
KB665	711 mm (28")	18 - 24 mm (0.70")-(0.94")	745 mm (29.3")	665 mm (26.2")	QL 200, SD-18 NUMA180/240	168 mm (6.6")
KB715	762 mm (30")	18 - 24 mm (0.70")-(0.94")	798 mm (31.4")	716 mm (28.2")	QL 200, SD-18 NUMA 180/240	168mm (6.6")
KB815	863 mm (34")	18 - 24 mm (0.70")-(0.94")	900 mm (35.4")	815 mm (32")	QL 200, SD-18 NUMA 240	168 mm (6.6")

## Double Casing Drilling Tools



### Application Range:

Suitable for geothermal drill for grouting, sampling, water well drill, foundation drill etc.

### Working Principles:

By using water or Compressed air the discharge head make the casing tube and drill rod rotate and penetrate

Structure:

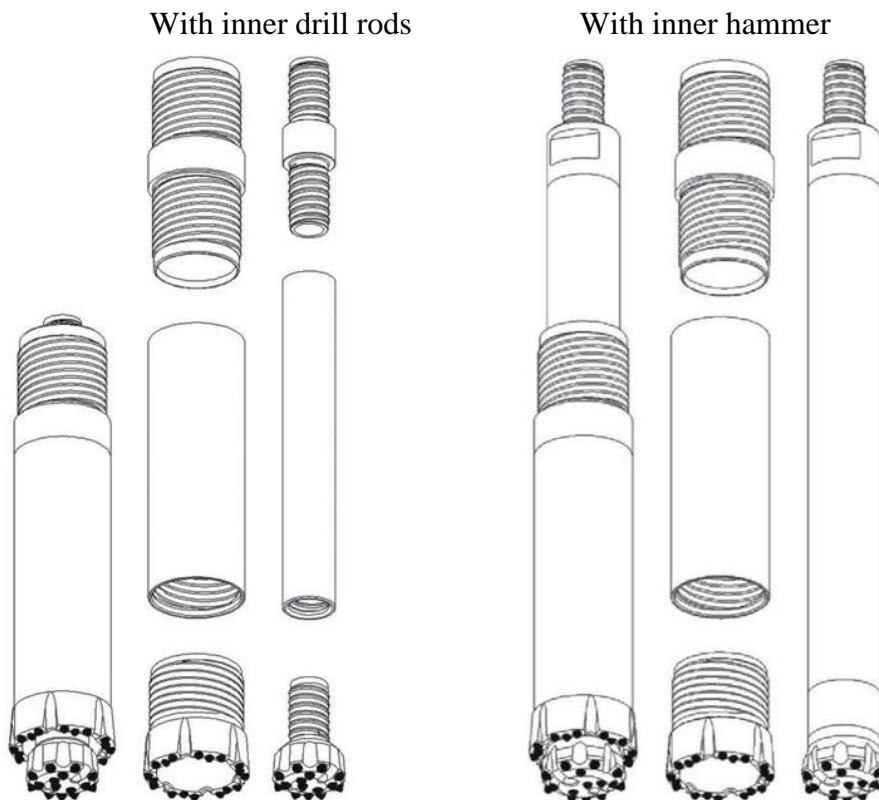

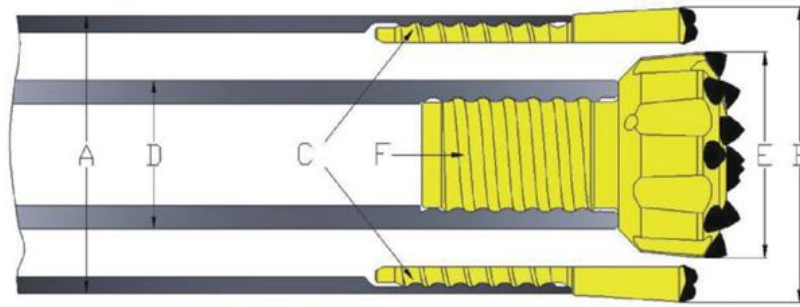

Ring Bit					Inner Bit				
A	B	C			D	E	F		
Outer Dia.	Bore Hole Dia.	Thread	Qty.× Button Dia. (mm)	Weight	Drill Rod Dia.	Drill Bit Dia.	Thread	Qty.×Button Dia.	Weight
118 mm (4.65")	125 mm (4.92")	104.2 mm (4.10")	12×13 /6×12	7.0 kg (15.4)lb.	73 mm (2.87")	85 mm (3.35")	R56	8×12 (6×11")	4.5 kg (9.92)lb.
133 mm (5.24")	142 mm (5.6")	122 mm (4.8")	12×13 /6×13	7.5 kg (16.5) lb.	73mm (2.87")	99 mm (3.9")	R56	8×14 (6×14")	5.0 kg (11) lb.
146 mm (5.75")	155 mm (6.10")	134 mm (5.25")	12×14 /4×13	8.0kg (17.6) lb.	73 mm (2.87")	115mm (4.53")	R56	8×14 (7×12")	6.0kg (13.2)lb.
168 mm (6.6")	175 mm (6.89")	154mm (6")	12×12 /6×12	10.5 kg (23.15)lb	73 mm (2.87")	127 mm (5")	R56	9×14 (8×14")	7.0 kg (15.4)lb.



**Kemaico USA Corporation**

Add: 300 Knightsbridge Pkwy Ste. 113  
Lincolnshire, IL 60069

Tel: 1-847-913-6878 Fax: 1-847 913 6879

Email: office@kemaico.com

Web: www.kemaico.com